

**Milwaukee**<sup>®</sup>

Nothing but **HEAVY DUTY**.<sup>®</sup>

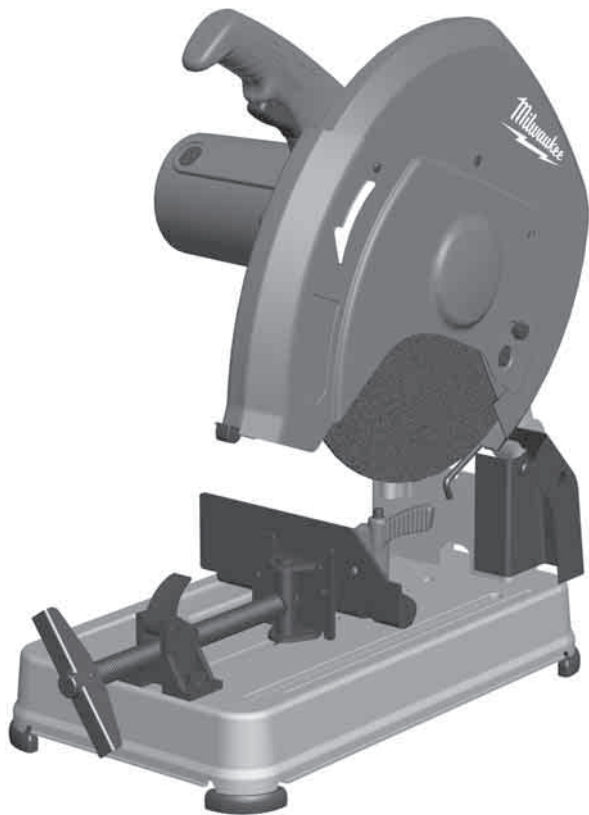

## **CHS 355**

Original instructions

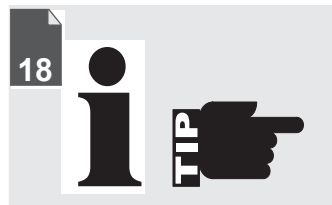
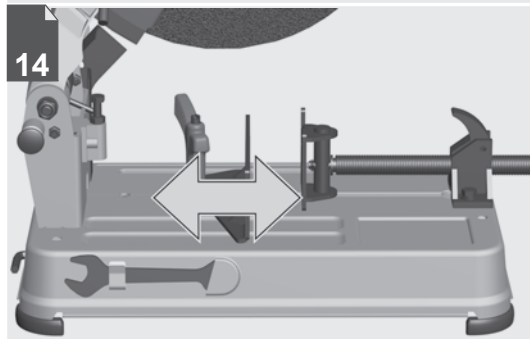
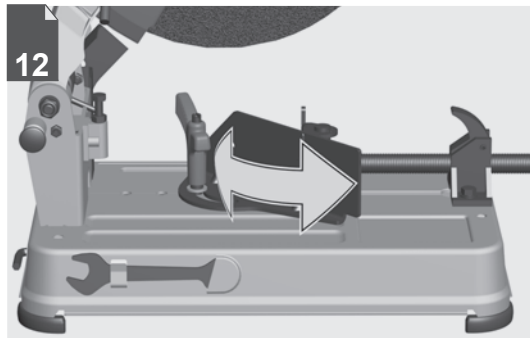
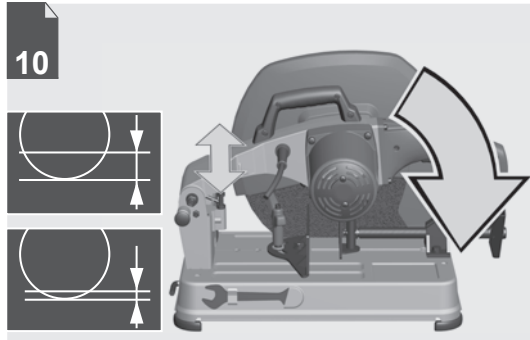
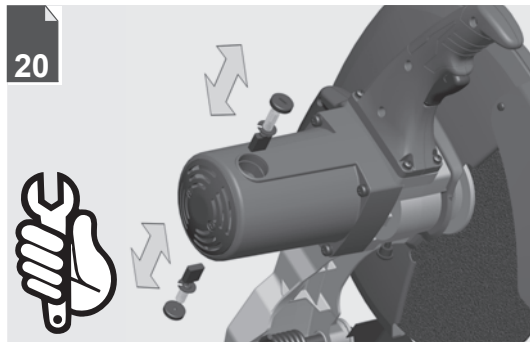

22

Text section with Technical Data, important Safety and Working Hints and description of Symbols

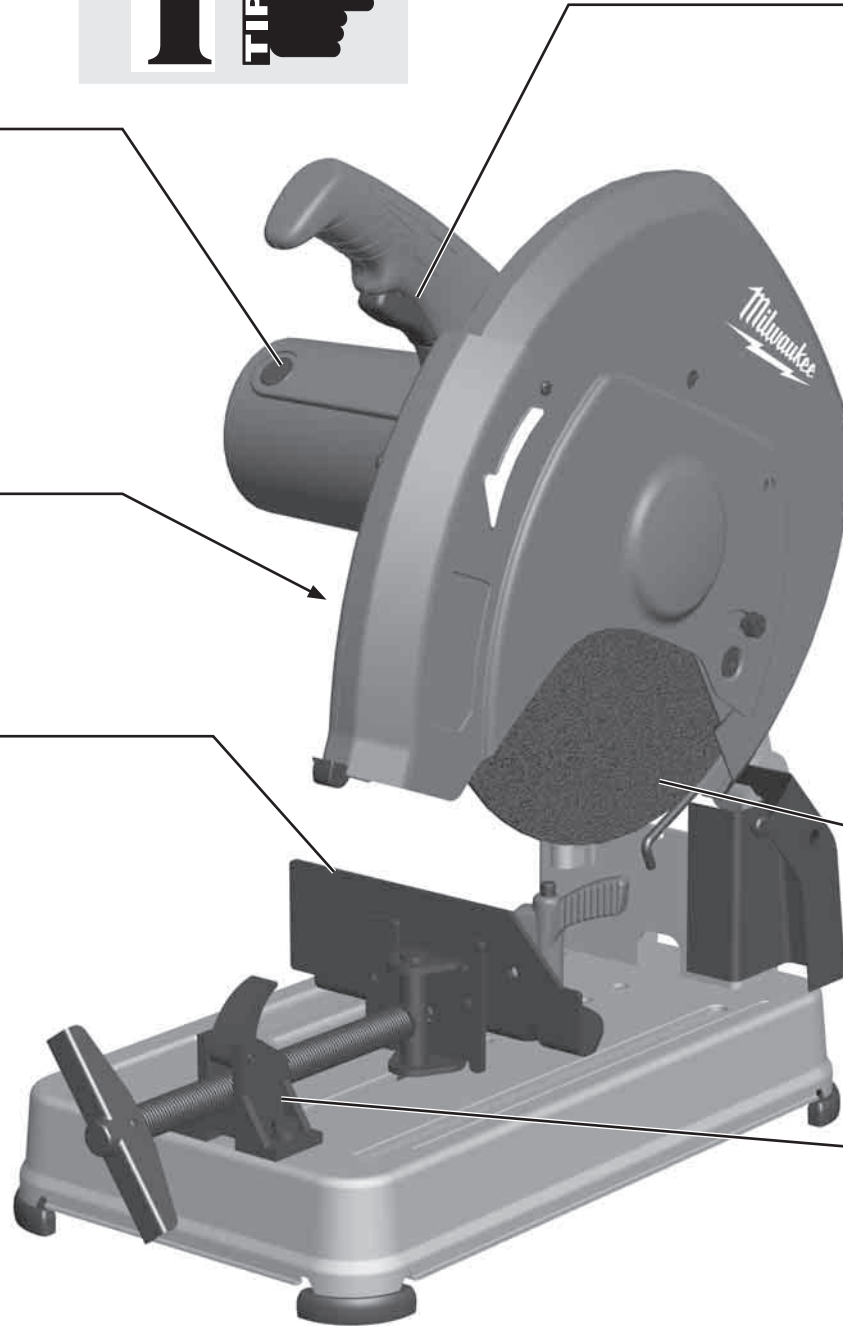
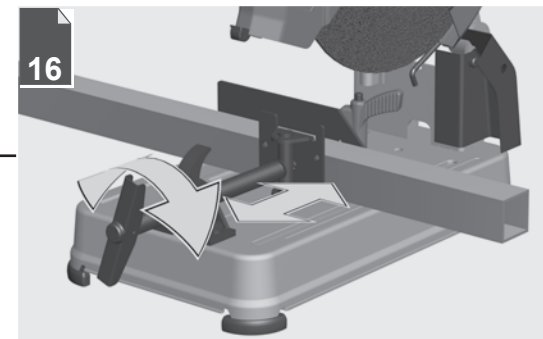
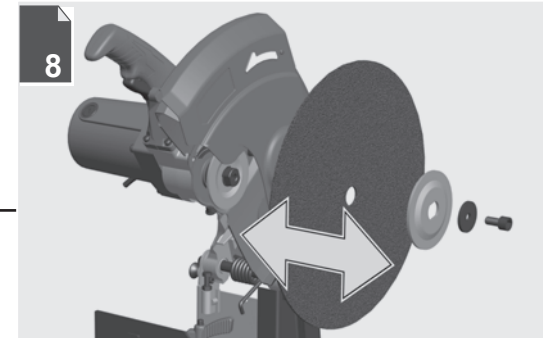
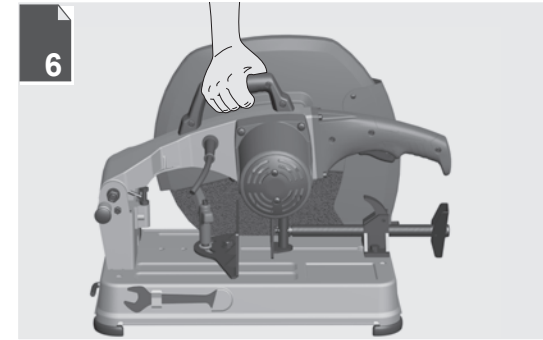
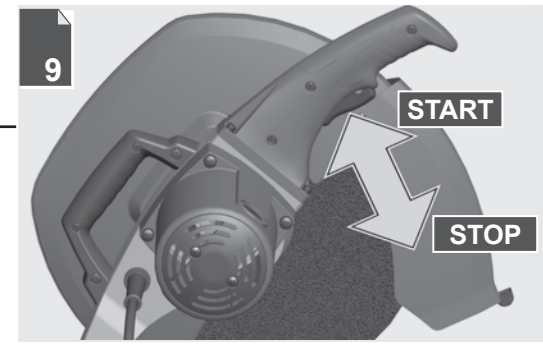

i

Description see text section.

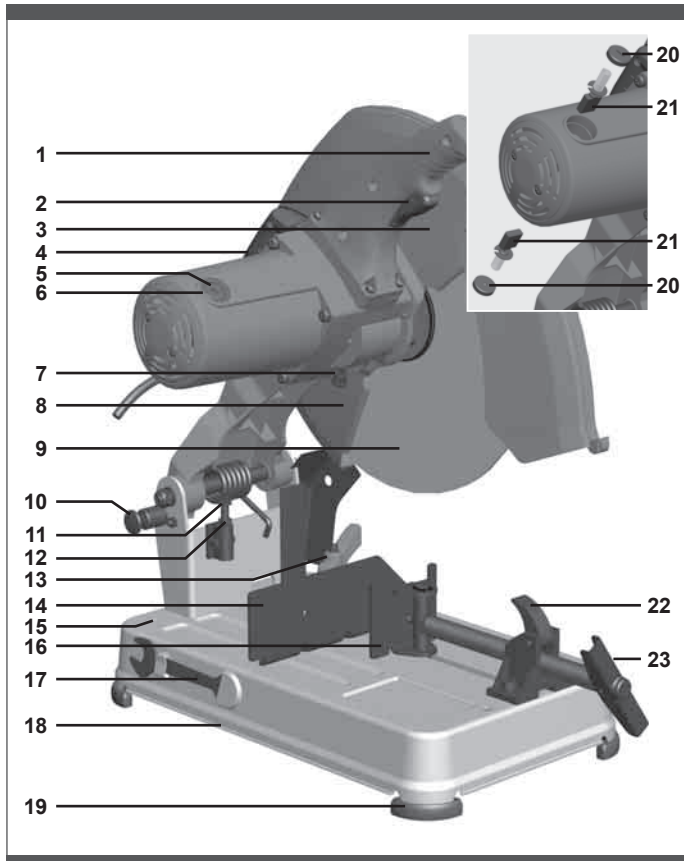

Accessory - Not included in standard equipment.

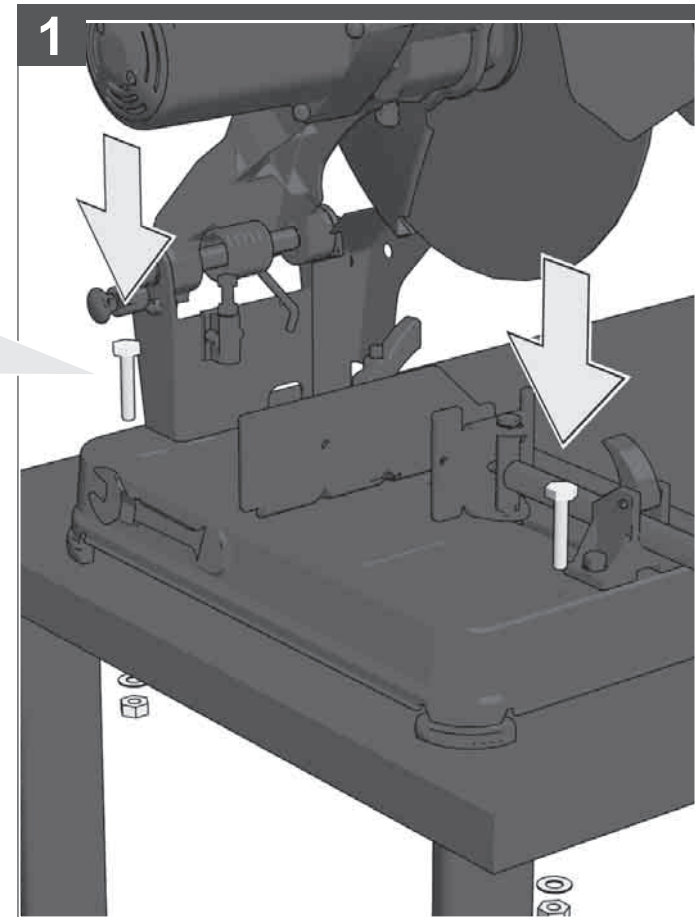

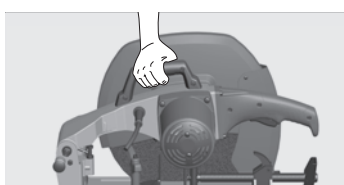

1

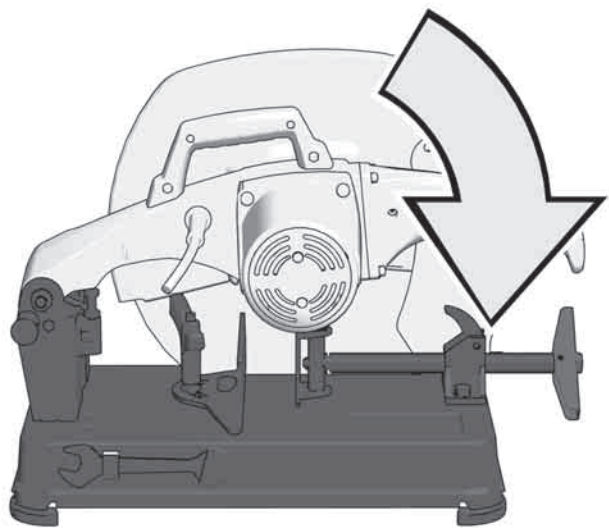

2

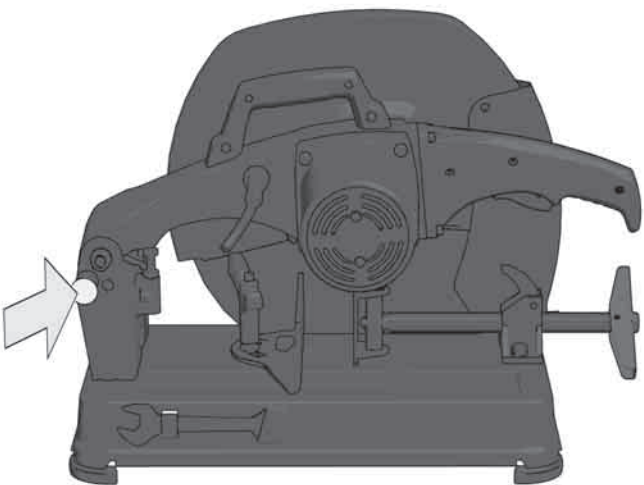

3

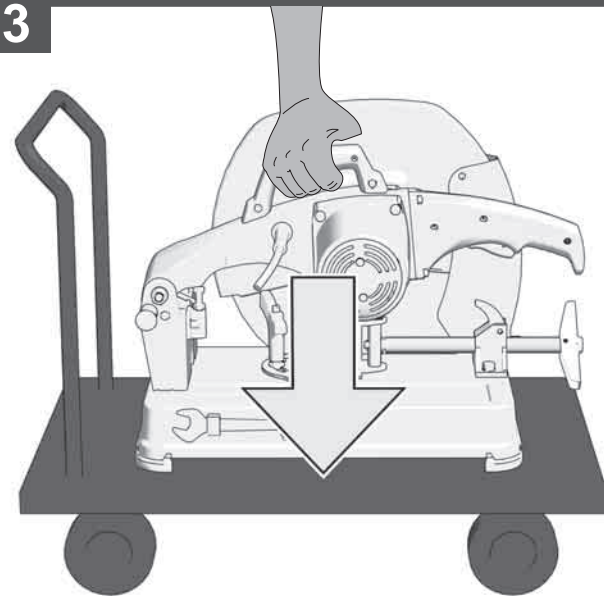

4

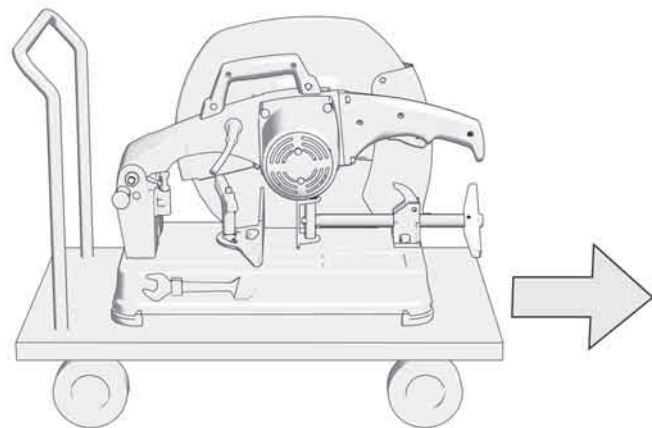

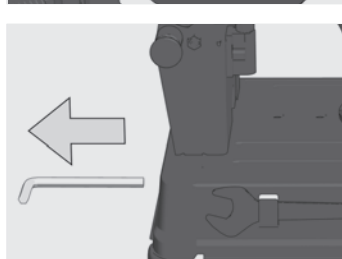
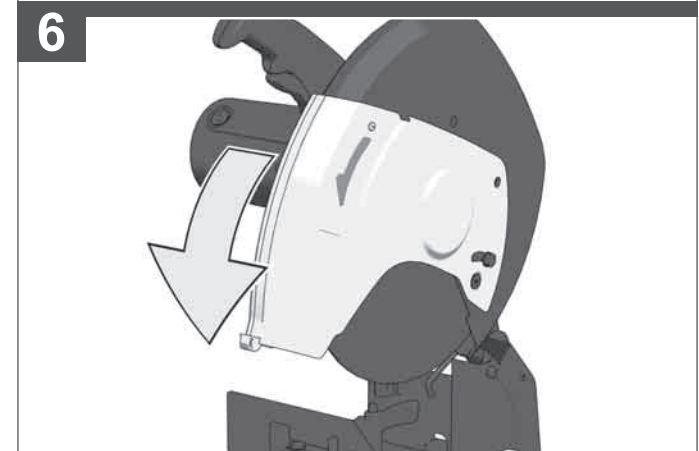
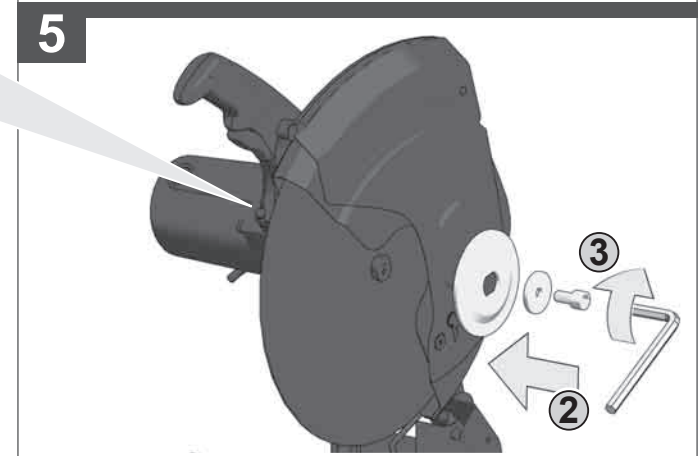
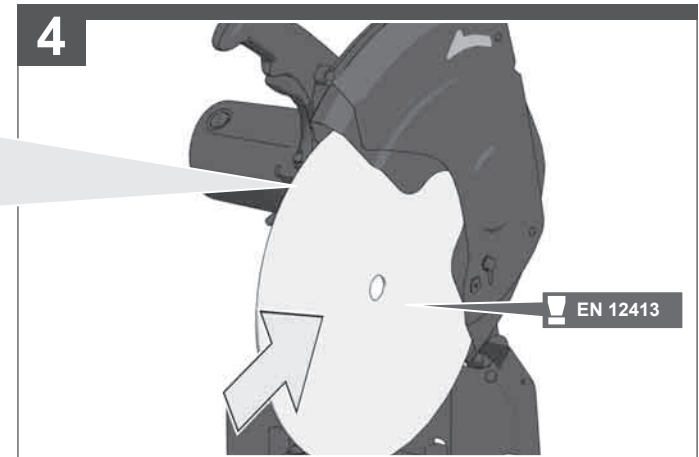
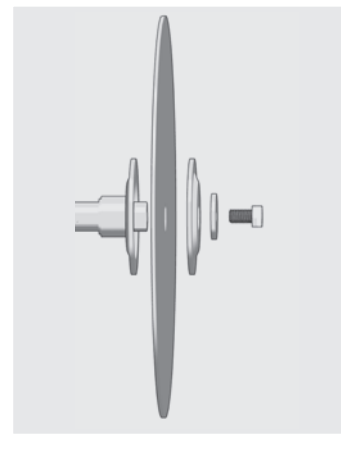
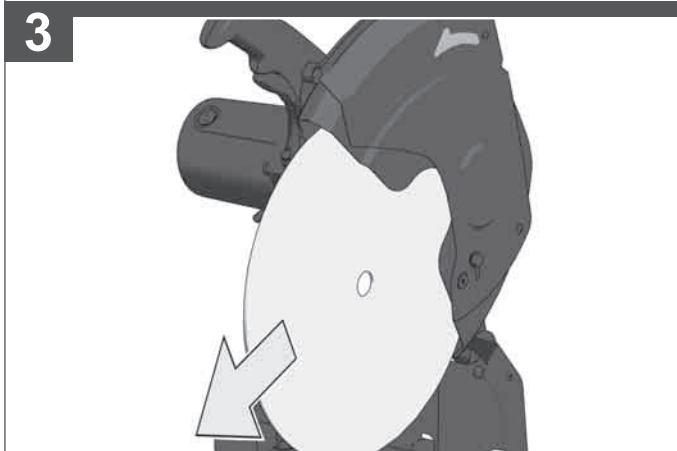
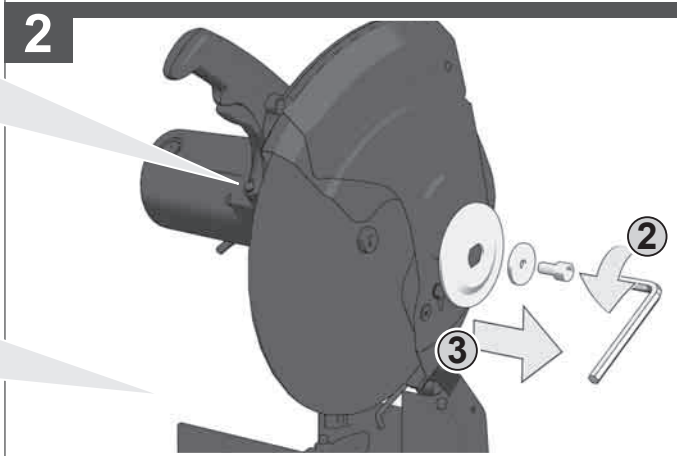
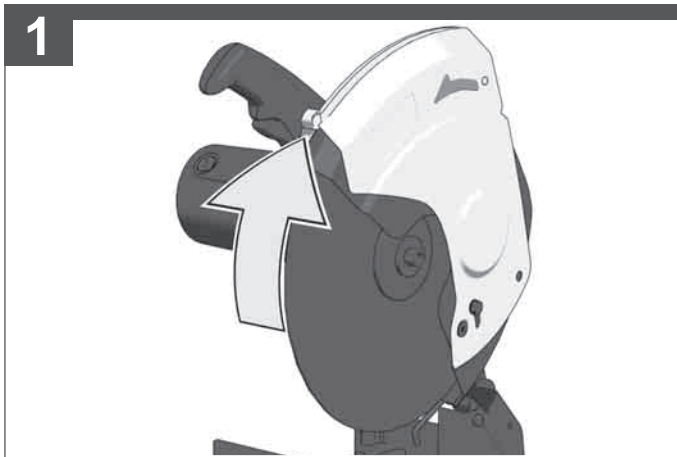

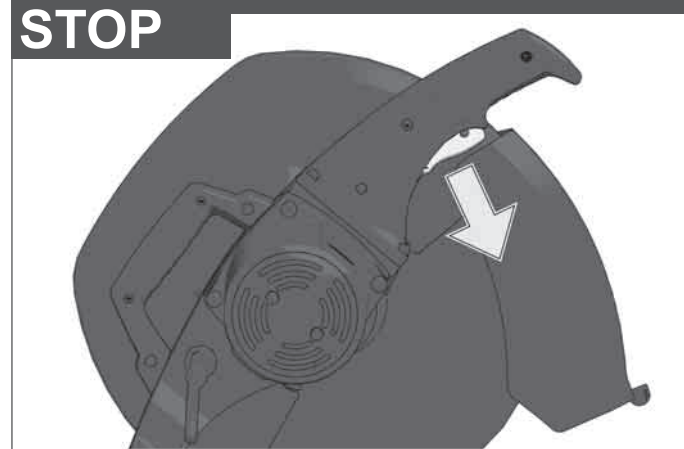
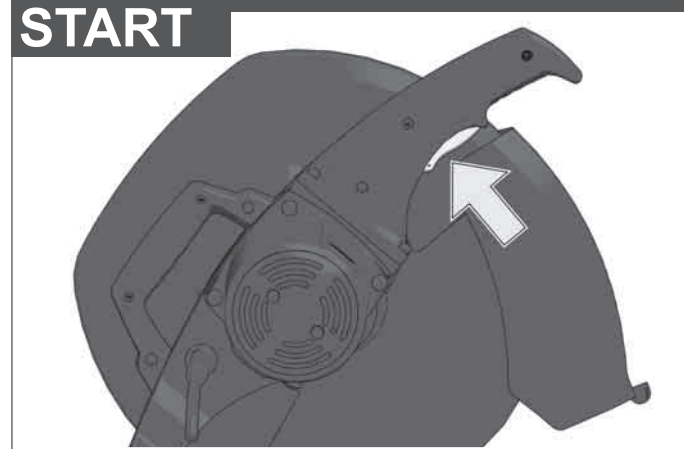
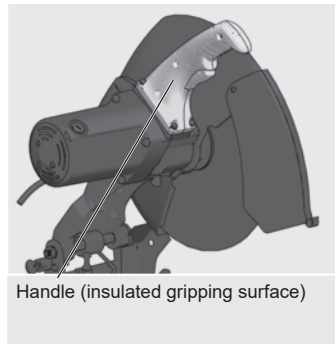
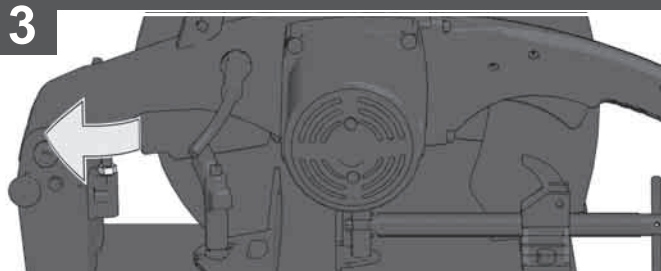
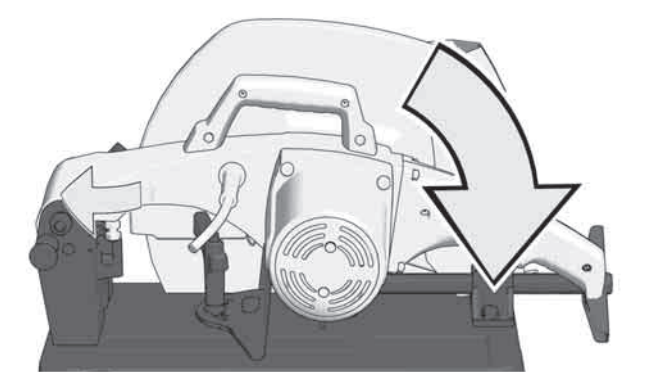
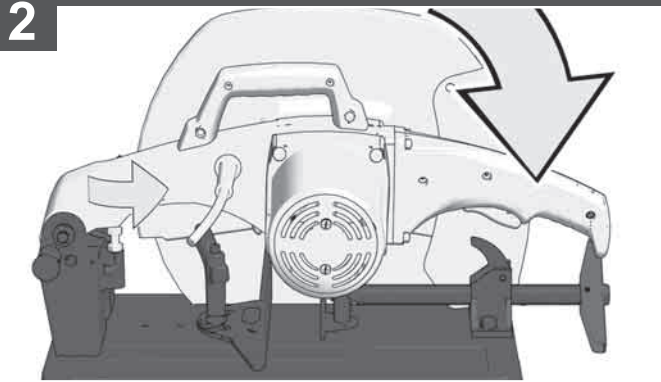
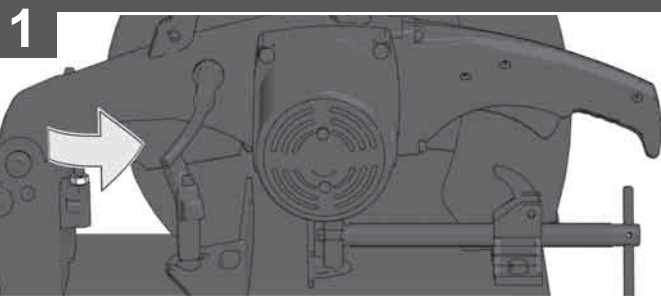
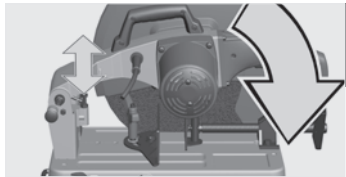

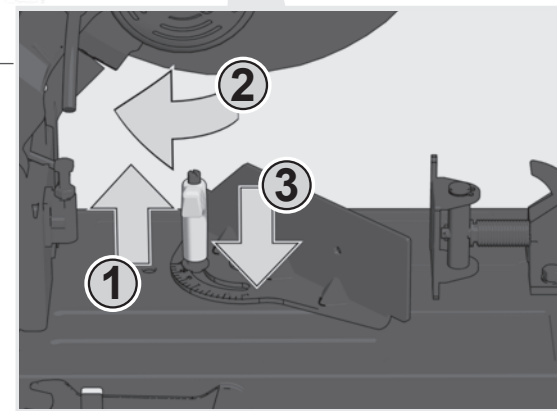
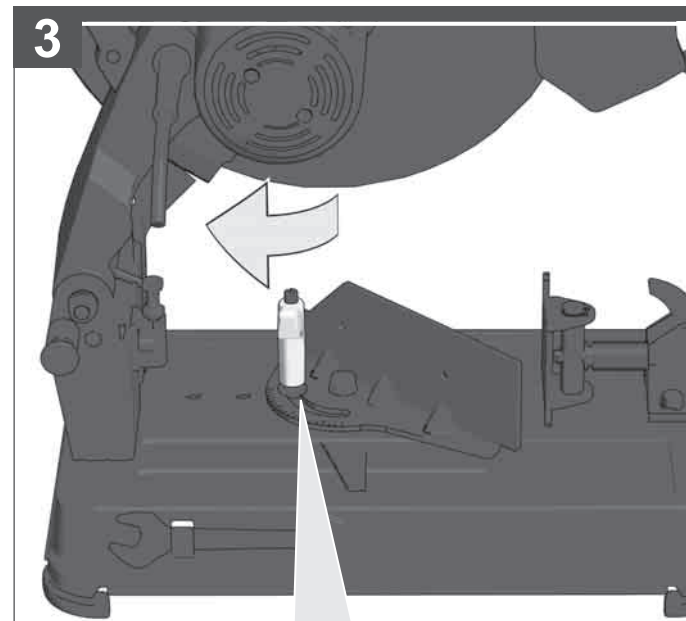
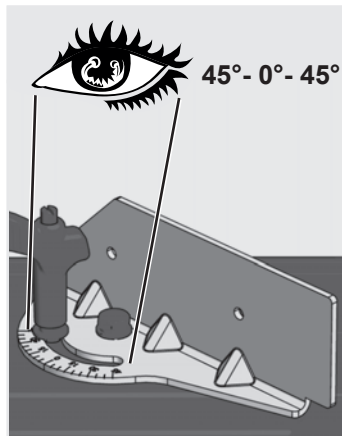
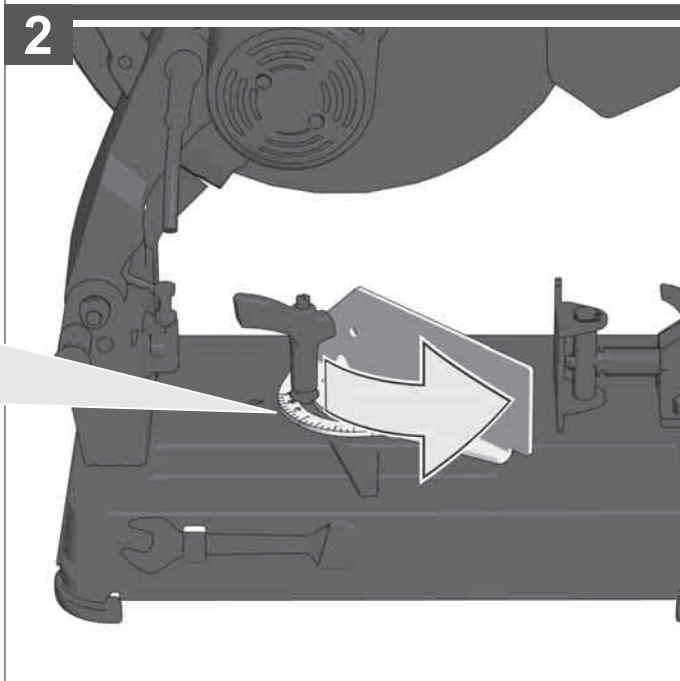
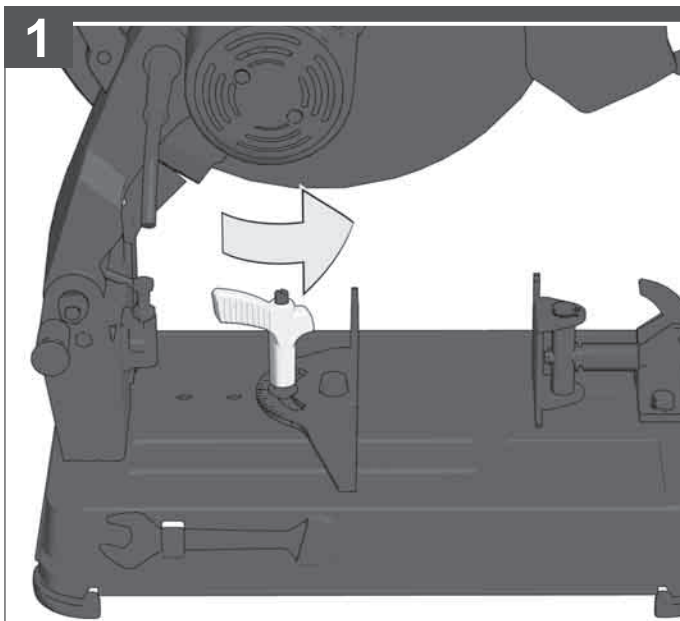
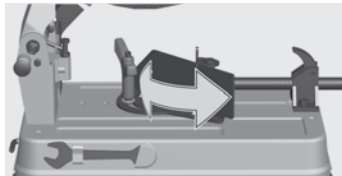

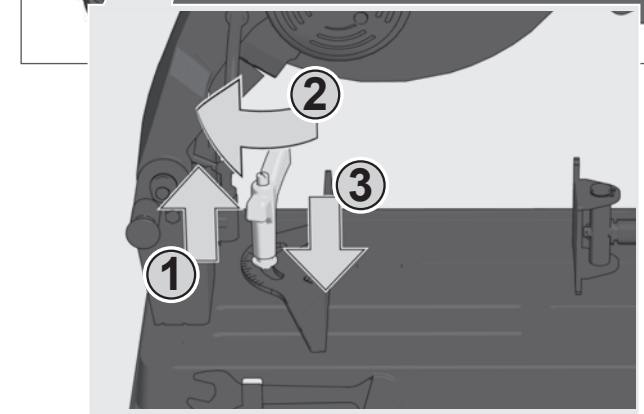
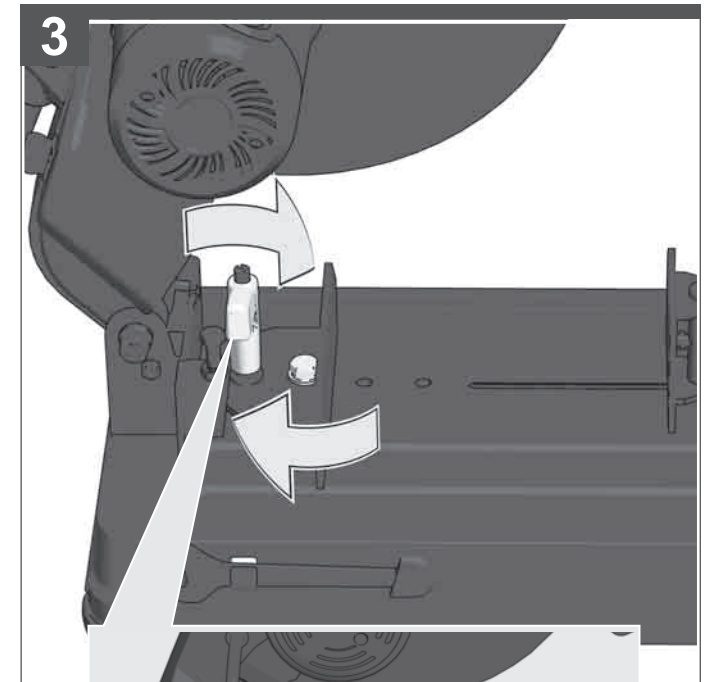
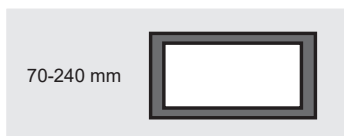
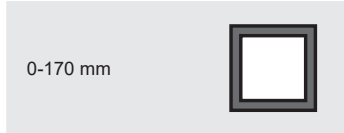
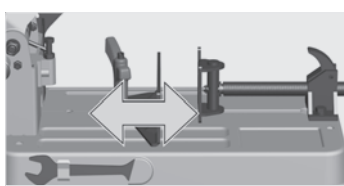
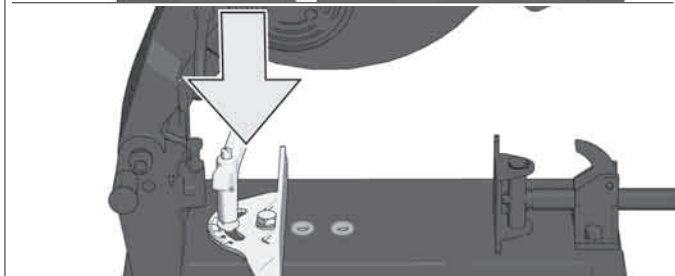
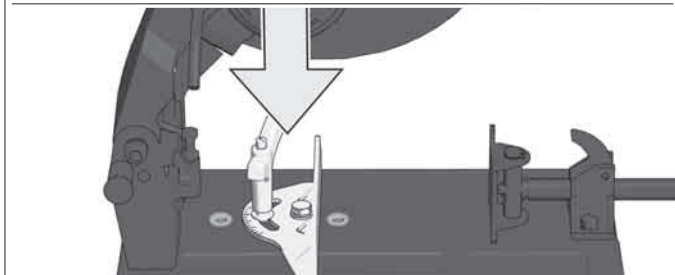
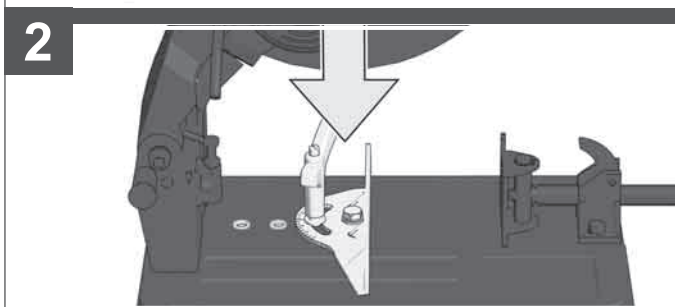
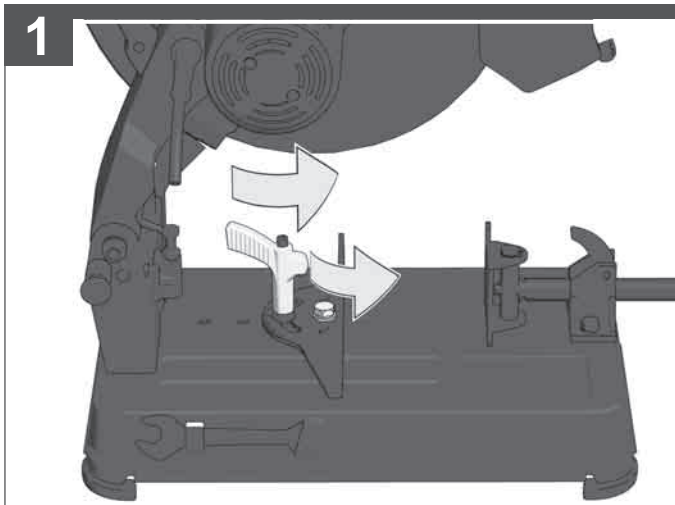



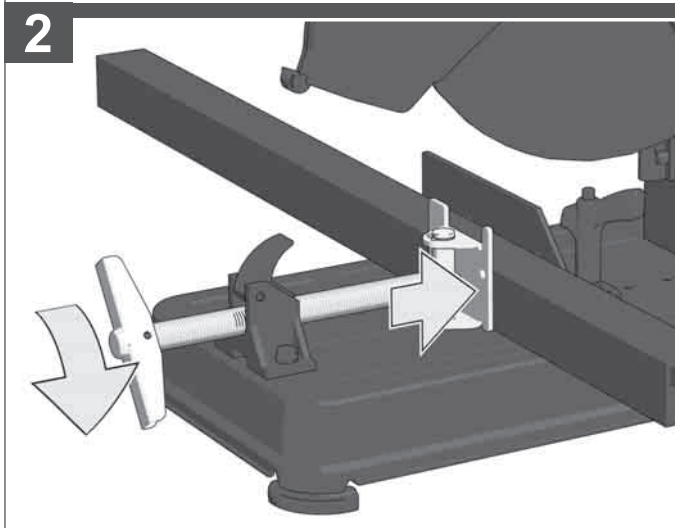
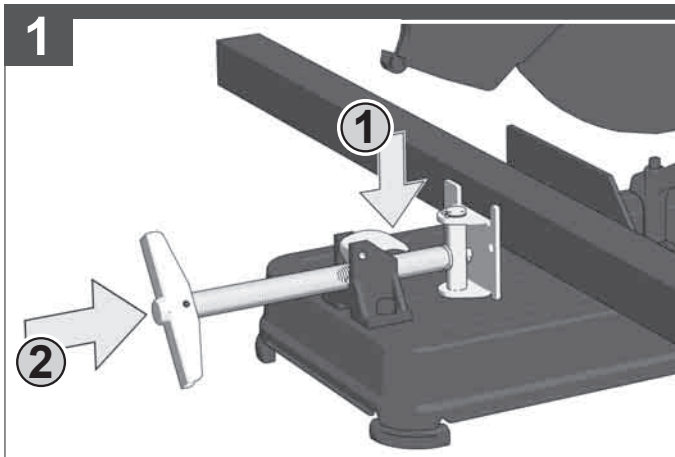



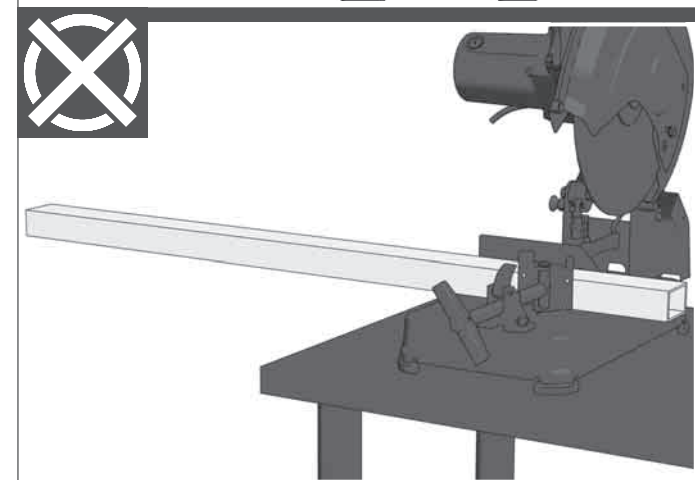
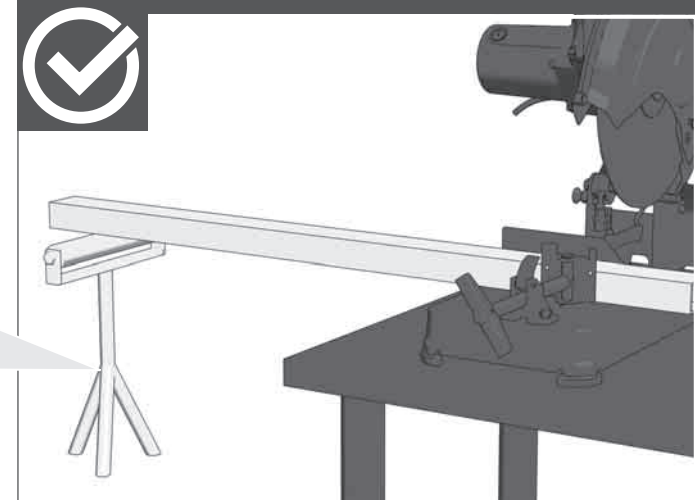



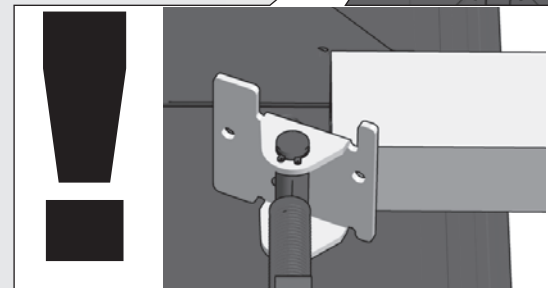
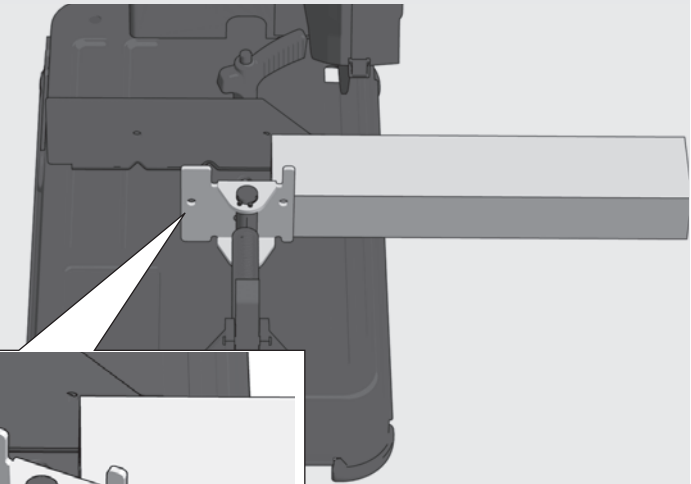
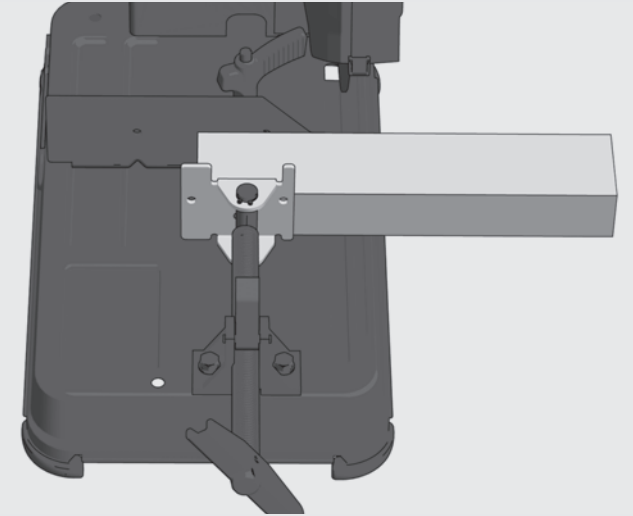
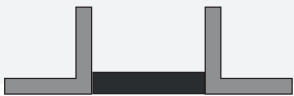
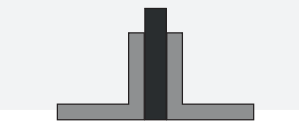
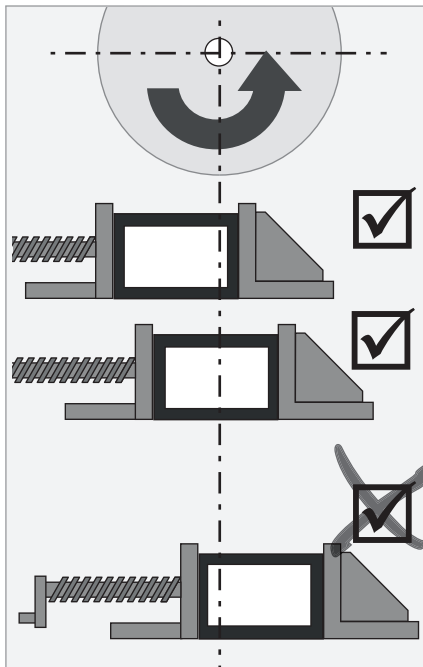
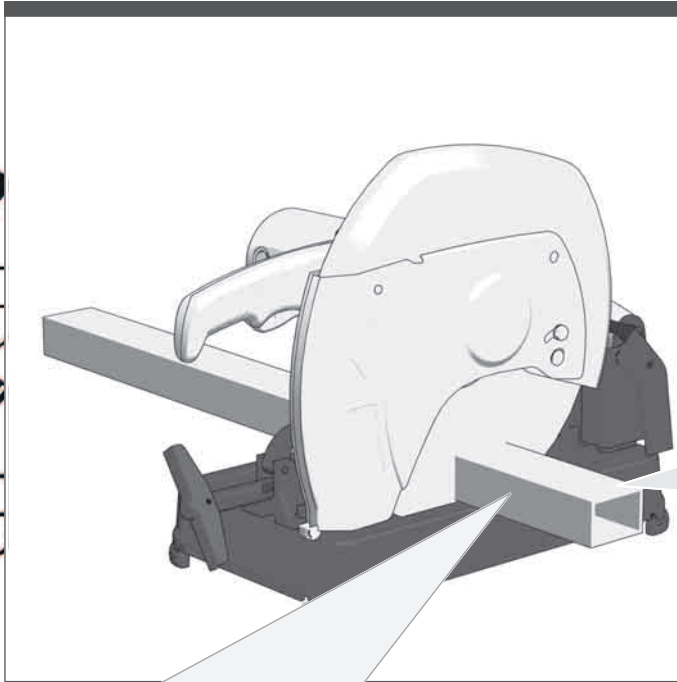
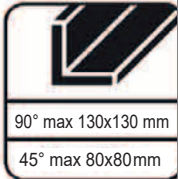
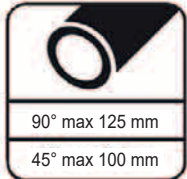
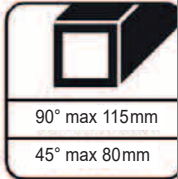
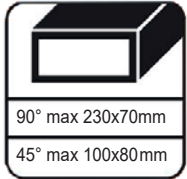

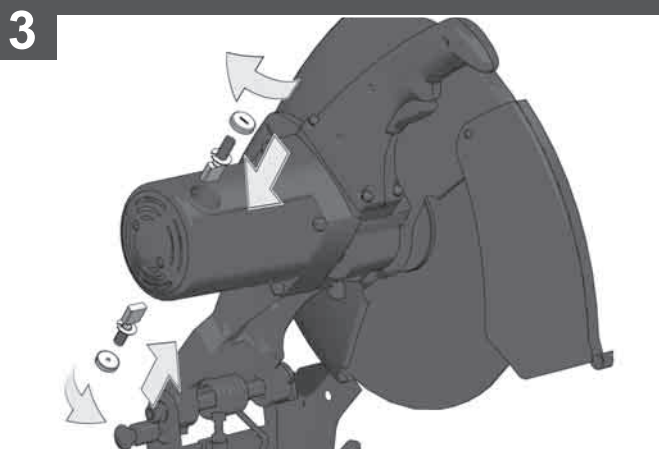
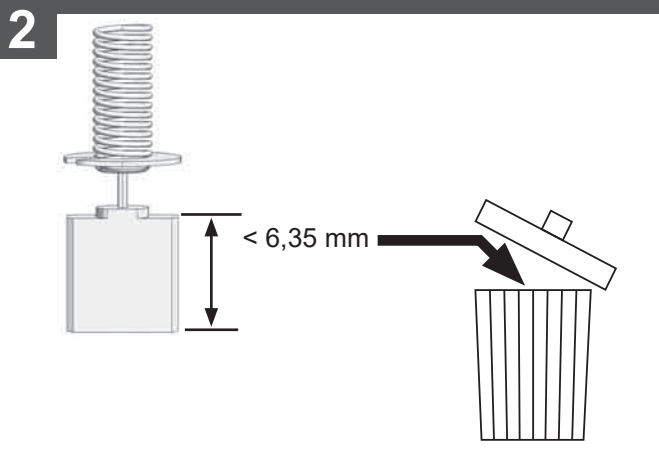
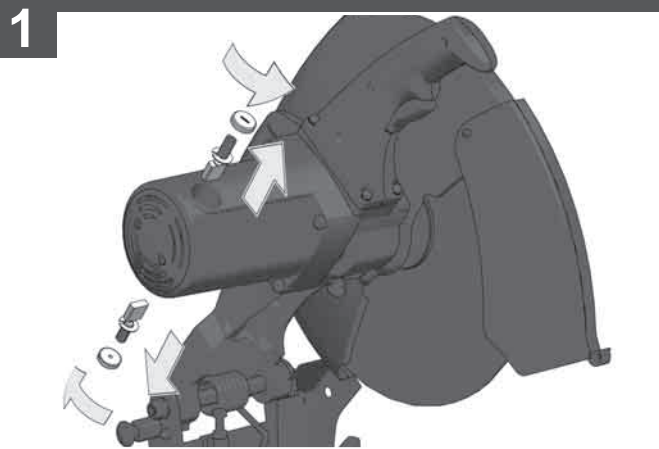
Accessory - Not included in standard equipment.



**i** **TIP** 





TECHNICAL DATA	METAL CUT-OFF MACHINE	CHS 355 (110-120 V)	CHS 355 (220-240 V)
Production code.....	4103 61 05.....	4117 61 05.....	4103 56 05.....
	...000001-999999	...000001-999999	
Rated input.....	1800 W.....	2300 W.....	
No-load speed.....	4100 min <sup>-1</sup> .....	4100 min <sup>-1</sup> .....	
Cut-off wheel diameter.....	355 mm.....	355 mm.....	
Hole diameter cut-off wheel.....	25,4 mm.....	25,4 mm.....	
Wheel thickness.....	3 mm.....	3 mm.....	
Wheel type: reinforced abrasive wheel.....	Type 41.....	Type 41.....	
Cutting capacity 0° 	120 x 110 mm.....	120 x 110 mm.....	
	115 mm.....	115 mm.....	
	115 mm.....	115 mm.....	
	125 mm.....	125 mm.....	
Cutting capacity 45° 	120 x 95 mm.....	120 x 95 mm.....	
	95 mm.....	95 mm.....	
	115 mm.....	115 mm.....	
	95 mm.....	95 mm.....	
Weight according EPTA-Procedure 01/2014.....	17,5 kg.....	17,5 kg.....	

#### Noise Information

Measured values determined according to EN 62841.

Typically, the A-weighted noise levels of the tool are:

Sound pressure level (Uncertainty K=3dB(A))..... 91 dB (A)..... 94,5 dB (A)

Sound power level (Uncertainty K=3dB(A))..... 104 dB (A)..... 107,5 dB (A)

#### Wear ear protectors!

#### WARNING

The noise emission level given in this information sheet has been measured in accordance with a standardized test given in EN 62841 and may be used to compare one tool with another. It may be used for a preliminary assessment of exposure.

The declared noise emission level represents the main applications of the tool. However if the tool is used for different applications, with different accessories or poorly maintained, noise emission may differ. This may significantly increase the exposure level over the total working period.

An estimation of the level of exposure to noise should also take into account the times when the tool is switched off or when it is running but not actually doing the job. This may significantly reduce the exposure level over the total working period.

Identify additional safety measures to protect the operator from the effects of noise such as: maintain the tool and the accessories and organization of work patterns.

**⚠ WARNING** Read all safety warnings, instructions, illustrations and specifications provided with this power tool. Failure to follow all instructions listed below may result in electric shock, fire and/or serious injury. Save all warnings and instructions for future reference.

#### ⚠ CUT-OFF MACHINE SAFETY WARNINGS

- Position yourself and bystanders away from the plane of the rotating wheel. The guard helps to protect the operator from broken wheel fragments and accidental contact with wheel.
- Use only bonded reinforced cut-off wheels for your power tool. Just because an accessory can be attached to your power tool, it does not assure safe operation.
- The rated speed of the accessory must be at least equal to the maximum speed marked on the power tool. Accessories running faster than their rated speed can break and fly apart.
- Wheels must be used only for recommended applications. For example: do not grind with the side of a cut-off wheel. Abrasive cut-off wheels are intended for peripheral grinding, side forces applied to these wheels may cause them to shatter.
- Always use undamaged wheel flanges that are of correct diameter for your selected wheel. Proper wheel flanges support the wheel thus reducing the possibility of wheel breakage.
- The outside diameter and the thickness of your accessory must be within the capacity rating of your power tool.

Incorrectly sized accessories cannot be adequately guarded or controlled.

- The arbour size of wheels and flanges must properly fit the spindle of the power tool. Wheels and flanges with arbour holes that do not match the mounting hardware of the power tool will run out of balance, vibrate excessively and may cause loss of control.
- Do not use damaged wheels. Before each use, inspect the wheels for chips and cracks. If the power tool or wheel is dropped, inspect for damage or install an undamaged wheel. After inspecting and installing the wheel, position yourself and bystanders away from the plane of the rotating wheel and run the power tool at maximum no load speed for one minute. Damaged wheels will normally break apart during this test time.
- Wear personal protective equipment. Depending on application, use face shield, safety goggles or safety glasses. As appropriate, wear dust mask, hearing protectors, gloves and shop apron capable of stopping small abrasive or workpiece fragments. The eye protection must be capable of stopping flying debris generated by various operations. The dust mask or respirator must be capable of filtering particles generated by your operation. Prolonged exposure to high intensity noise may cause hearing loss.
- Keep bystanders a safe distance away from work area. Anyone entering the work area must wear personal protective equipment. Fragments of workpiece or of a broken wheel may fly away and cause injury beyond immediate area of operation.

k) Position the cord clear of the spinning accessory. If you lose control, the cord may be cut or snagged and your hand or arm may be pulled into the spinning wheel.

l) Regularly clean the power tool's air vents. The motor's fan can draw the dust inside the housing and excessive accumulation of powdered metal may cause electrical hazards.

m) Do not operate the power tool near flammable materials. Do not operate the power tool while placed on a combustible surface such as wood. Sparks could ignite these materials.

n) Do not use accessories that require liquid coolants. Using water or other liquid coolants may result in electrocution or shock.

#### Kickback and related warnings

Kickback is a sudden reaction to a pinched or snagged rotating wheel. Pinching or snagging causes rapid stalling of the rotating wheel which in turn causes the uncontrolled cutting unit to be forced upwards toward the operator.

For example, if an abrasive wheel is snagged or pinched by the workpiece, the edge of the wheel that is entering into the pinch point can dig into the surface of the material causing the wheel to climb out or kick out. Abrasive wheels may also break under these conditions.

Kickback is the result of power tool misuse and/or incorrect operating procedures or conditions and can be avoided by taking proper precautions as given below.

- Maintain a firm grip on the power tool and position your body and arm to allow you to resist kickback forces. The operator can control upward kickback forces, if proper precautions are taken.
- Do not position your body in line with the rotating wheel. If kickback occurs, it will propel the cutting unit upwards toward the operator.
- Do not attach a saw chain woodcarving blade or toothed saw blade. Such blades create frequent kickback and loss of control.
- Do not "jam" the wheel or apply excessive pressure. Do not attempt to make an excessive depth of cut. Overstressing the wheel increases the loading and susceptibility to twisting or binding of the wheel in the cut and the possibility of kickback or wheel breakage.
- When the wheel is binding or when interrupting a cut for any reason, switch off the power tool and hold the cutting unit motionless until the wheel comes to a complete stop. Never attempt to remove the wheel from the cut while the wheel is in motion otherwise kickback may occur. Investigate and take corrective action to eliminate the cause of wheel binding.
- Do not restart the cutting operation in the workpiece. Let the wheel reach full speed and carefully re-enter the cut. The wheel may bind, walk up or kickback if the power tool is restarted in the workpiece.
- Support any oversized workpiece to minimize the risk of wheel pinching and kickback. Large workpieces tend to sag under their own weight. Supports must be placed under the workpiece near the line of cut and near the edge of the workpiece on both sides of the wheel.

#### ADDITIONAL SAFETY AND WORKING INSTRUCTIONS

Always use eye and ear protection when cutting.

Use personal protective equipment such as dust mask, gloves and apron. If there is the risk of falling object, wear helmet or head protection.

Ensure that the abrasive cutting-off wheel is correctly fitted and tightened before use and run the machine at no-load for 30 seconds in a safe position, and to stop immediately and replace the cutting-off wheel if there is considerable vibration.

Before making a cut, be sure all adjustments are secure.

Before performing any adjustment, make sure the tool is disconnected from the power supply. Failure to disconnect the power supply could result in accidental starting causing possible serious personal injury.

Assemble all parts to your cut-off machine before connecting it to power supply.

The product should never be connected to the power supply when you are assembling parts, making adjustments, installing or removing wheels, or when not in use.

Visually inspect the abrasive wheel before every use. Check the wheel for fissures and cracks. Do not use damaged abrasive wheel.

Do not use saw blades.

Never use a wheel that is too thick to allow outer flange to engage with the flats on the spindle. Larger wheels will come in contact with the wheel guards, while thicker wheels will prevent the bolt from securing the wheel on the spindle. Either of these situations could result in a serious accident and can cause serious personal injury.

Do not remove the machine's wheel guards. Never operate the machine with any guard or cover removed. Make sure all guards are operating properly before each use.

Do not start your cut-off machine without checking for interference between the wheel and the machine base support. Damage may result to the wheel if it strikes the machine base support during operation.

Do not attempt to cut wood or masonry with the cut-off machine. Never cut magnesium or magnesium alloy with the machine.

Do not tighten wheel excessively, since this can cause cracks.

Always ease the abrasive wheel against the workpiece when starting to cut. A harsh impact can break the wheel.

Never cut more than one workpiece at a time. Do not stack more than one workpiece on the machine base at a time.

To minimise risk of tipping the machine, always support long workpieces.

Cutting steel will cause sparks. Do not operate in the presence of combustible or flammable materials.

Never leave tool running unattended. Do not leave tool until it comes to a complete stop.

Always release the power switch and allow the wheel to stop rotating before raising it out of the workpiece.

Keep hands away from cutting area. Keep hands away from wheel.

Do not reach underneath work or around or under the wheel while the wheel is rotating. Do not attempt to remove cut material while wheel is moving.

Never stand or have any part of your body in line with the path of the wheel.

Never stand on the tool. Serious injury could occur if the tool is tipped or if the wheel is unintentionally contacted.

Never perform any operation "freehand". Always secure the workpiece to be cut in the vice. Refer to specifications table for safe minimum size of workpiece. Always ensure you grip at least 80 mm in the vice jaws to ensure security while grinding.

Never hand hold a workpiece; it will become very hot while being cut.

A power spike causes voltage fluctuations and may affect other electrical products in the same power line. Connect the product to a power supply with an impedance equal to 0.233 Ω to minimize voltage fluctuations. Contact your electric power supplier for further clarification.

It is recommended that the tool always be supplied via a residual current device having a rated residual current of 30mA or less.

Milwaukee recommends that you use Metal Cutting Wheel 41A24RBF80 as a replacement whenever you need a new wheel.

## SAFETY WARNINGS FOR FITTING AN ABRASIVE WHEEL

To reduce the risk of injury, user must read and comply with instructions, warnings and operator's manual before starting to use the abrasive wheel. Failure to heed these warnings can result in wheel breakage and serious personal injury. Save these instructions.

The use of any wheel other than the one recommended in the machine instruction manual may present a risk of personal injury. Use only abrasive wheels which have marked speed equal or greater to that marked on the machine.

Never use abrasive wheel that is too thick to allow outer flange to engage with the flats on the spindle. Larger wheels will come in contact with the wheel guards, while thicker wheels will prevent the bolt from securing the wheel on the spindle. Either of these situations could result in a serious accident and can cause serious personal injury.

This abrasive wheel is for ferrous metal cutting only. Do not attempt to cut wood or masonry with it. Never cut magnesium or magnesium alloy with it.

This abrasive wheel is only suitable for dry cutting, and should be used before the date of expiry (marking on arbour hole e.g., V07/2019).

Do not use damaged abrasive wheels. Do not use wheels that are chipped, cracked or otherwise defective.

Ensure that the abrasive cutting-off wheel is correctly fitted and tightened before use.

The direction of rotation of the abrasive wheel is indicated on the tool. Make sure the direction mark on wheel is consistent with the direction identified on the tool while installing and changing abrasive wheel.

Do not tighten abrasive wheel excessively, since this can cause cracks.

The cut-off machine should never be connected to power supply when you are installing or removing abrasive wheels.

Store your spare abrasive wheels carefully; they can be damaged easily.

## Information available on the abrasive wheel label

The information on the wheel label is IMPORTANT. Read and check it carefully to ensure you are selecting the correct type of wheel.

1. Manufacturer, supplier, importer or trade mark
2. Nominal dimensions of abrasive wheel, in particular the diameter of the bore

3. Abrasive type, grain size, grade or hardness, type of bond and use of reinforcement e.g. 41A24RBF80.  
41 -> abrasive type, flat cutting-off wheel  
A -> abrasive material: brown corundum  
24 -> grain size  
R -> grade or hardness  
BF -> type of bond  
80 -> maximum operating speed m/s

4. Maximum operation speed in metres per second
5. Maximum permissible speed of rotation in 1/min
6. For declaration of conformity, the abrasive products shall be marked with EN 12413
7. Restriction of use and safety warning symbols.
8. Traceability code, eg. A production/batch number, expiry date or series number

## RESIDUAL RISK

Even when the product is used as prescribed, it is still impossible to completely eliminate certain residual risk factors. The following hazards may arise in use and the operator should pay special attention to avoid the following:

- Stability. Ensure the tool is stable, if necessary secure it.
- Inhalation of dust. Wear a mask if necessary.
- Sparks and hot metal particles, these can cause fire, skin burns. Wear protective equipment during using.
- Eye injury from metal particles. Wear eye protection when working.
- Hearing injury – restrict exposure and wear appropriate hearing protection.

## TRANSPORTATION AND STORAGE

The handle must be always secured by the safety knob when transporting the cut-off machine.

Only transport the cut-off machine on a trolley.

Store the cut-off machine in a dry place and with secured Head.

## KNOW YOUR PRODUCT

- 1 Handle, insulated gripping surface
- 2 Trigger switch
- 3 Upper guard
- 4 Top handle
- 5 Carbon brush cap
- 6 Carbon brush
- 7 Spindle lock
- 8 Lower guard
- 9 Cutting wheel
- 10 Head lock safety knob
- 11 Cutting depth adjustment screw
- 12 Cutting depth lock nut
- 13 Mitre guide lock lever
- 14 Mitre guide
- 15 Mounting hole
- 16 Work clamp
- 17 Wrench
- 18 Work table
- 19 Rubber foot
- 20 Carbon brush cap
- 21 Carbon brush
- 22 Work clamp lock lever
- 23 Work clamp adjustment crank
- 24 Chip deflector

## SPECIFIED CONDITIONS OF USE

The metal cut-off machine is intended to be used for cutting metal materials. Do not use for non-metal materials.

The product is intended to be used only by adult operators who have read the instruction manual and understand the risks and hazards.

The product is intended to be fixed at the base to a solid bench top. If the base is not securely fixed the whole machine may move during cutting operations, which increases the possibility of serious personal injury.

The product is to be used in dry conditions, with excellent ambient lighting and adequate ventilation.

The product is intended for consumer use and should only be used as described above and is not intended for any other purpose.

Do not use this product in any other way as stated for normal use.

## EC-DECLARATION OF CONFORMITY

We declare under our sole responsibility that the product described under "Technical Data" fulfills all the relevant provisions of the directives 2011/65/EU (RoHS), 2014/30/EU, 2006/42/EC and the following harmonized standards have been used:

EN 62841-1:2015  
EN 62841-3-10:2015+A11:2017  
EN 55014-1:2017+A11:2020  
EN 55014-2:2015  
EN 61000-3-2:2014  
EN 61000-3-11:2000  
EN IEC 63000:2018

Winnenden, 2020-10-22



Alexander Krug  
Managing Director



Authorized to compile the technical file.

Techtronic Industries GmbH  
Max-Eyth-Straße 10  
71364 Winnenden  
Germany

## GB-DECLARATION OF CONFORMITY

We declare as the manufacturer under our sole responsibility that the product described under "Technical Data" fulfills all the relevant provisions of the following Regulations S.I. 2008/1597 (as amended), S.I. 2016/1091 (as amended), S.I. 2012/3032 (as amended) and that the following designated standards have been used:

BS EN 62841-1:2015  
BS EN 62841-3-10:2015+A11:2017  
BS EN 55014-1:2017+A11:2020  
BS EN 55014-2:2015  
BS EN 61000-3-2:2014  
BS EN 61000-3-11:2000  
BS EN IEC 63000:2018

Winnenden, 2020-10-22



Alexander Krug  
Managing Director

Authorized to compile the technical file.

Techtronic Industries GmbH  
Max-Eyth-Straße 10  
71364 Winnenden  
Germany

## MAINS CONNECTION

Connect only to single-phase a.c. current and only to the system voltage indicated on the rating plate. It is also possible to connect to sockets without an earthing contact as the design conforms to safety class II.

## MAINTENANCE

Do not make any adjustments while the motor is in motion.

Always make sure the machine's plug has been removed from the mains power source before changing brushes, lubricating or when doing any works or maintenance on the machine.

After each use, check your machine for damage or broken parts and keep it in top working condition by repairing or replacing parts immediately. Clean out accumulated dust.

To assure safety and reliability, all repairs with the exception of externally accessible brushes should be performed by an authorized service centre.

If the power supply cord is damaged, it must be replaced only by the manufacturer or by an authorized service center to avoid risk. Contact authorized service center.

The ventilation slots of the machine must be kept clear at all times.

Use only Milwaukee accessories and Milwaukee spare parts. Should components need to be replaced which have not been described, please contact one of our Milwaukee service agents (see our list of guarantee/service addresses).

If needed, an exploded view of the tool can be ordered. Please state the machine type printed as well as the six-digit No. on the label and order the drawing at your local service agents or directly at: Techtronic Industries GmbH, Max-Eyth-Straße 10, 71364 Winnenden, Germany.

## REPLACEMENT PARTS

Cutting wheel (see page 6, part 9)

## SYMBOLS



CAUTION! WARNING! DANGER!



Always disconnect the plug from the socket before carrying out any work on the machine.



Please read the instructions carefully before starting the machine.



Always wear goggles when using the machine.

Wear ear protectors!

Wear a suitable dust protection mask.



Wear gloves!



Do not dispose of electric tools together with household waste material.  
Electric tools and electronic equipment that have reached the end of their life must be collected separately and returned to an environmentally compatible recycling facility.  
Check with your local authority or retailer for recycling advice and collection point.



Class II tool.  
Tool in which protection against electric shock does not rely on basic insulation only, but in which additional safety precautions, such as double insulation or reinforced insulation, are provided.  
There being no provision for protective earthing or reliance upon installation conditions.



Not allowed for free-hand grinding.



Not allowed for side grinding.



Replace damaged cutting disc.



Do not expose to rain or use in damp locations.



Not for wet grinding or cutting.



For metal material cutting



Rotation direction



No-load speed



Volts



AC Current



European Conformity Mark



British Conformity Mark



Ukraine Conformity Mark



EurAsian Conformity Mark

Copyright 2020

Techtronic Industries GmbH  
Max-Eyth-Str. 10  
71364 Winnenden  
Germany

+49 (0) 7195-12-0

[www.milwaukeeeetool.eu](http://www.milwaukeeeetool.eu)

Techtronic Industries (UK) Ltd  
Fieldhouse Lane  
Marlow Bucks SL7 1HZ  
UK



**EAC UK  
CA**

(10.20)

**4100 4141 04**